

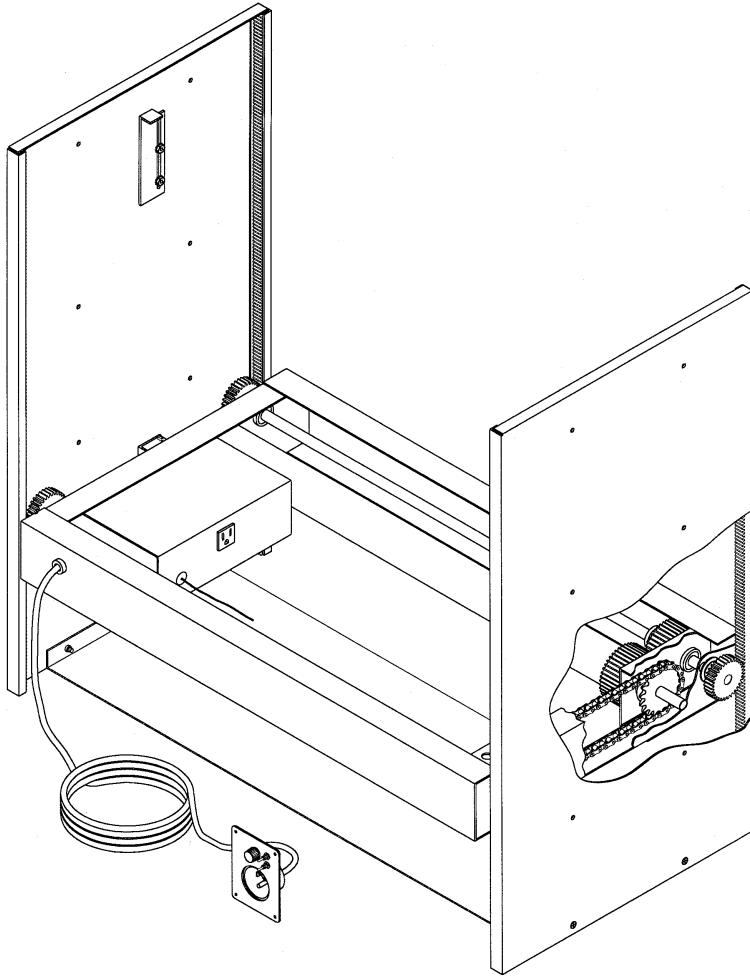

TV LIFT P/N 900200

1632-1/2 West 134th Street, Gardena, California 90249
(310) 808-0001 Fax (310) 808-9092 www.inca-tvlifts.com



The Inca lift is a motorized rack and pinion lifting machine providing the least costly solution to concealing your TV in a cabinet. This lift has a standard, fit all size, to accommodate the most commonly found televisions. The robust lifting capacity of 200 lbs allows this machine to support a wide range of applications.

The lift uses a newly designed steel platform, when coupled with a set of Inca formed aluminum rack gear side panels, provides a new high quality, yet low cost lift. All metal parts are formed on precision dies, or under rigorous computer control. Assembly of the steel platform is done through fusing the steel parts, to form a rigid and precise lifting machine. The easy adjustable, external limit switch cams, stop the platform motion precisely where you want it, each and every time.

Every lift comes equipped with both an internal built in radio remote control and a manual rocker switch control. The rocker switch is mounted on a simple, clean external access panel, which mounts on the wall of the furniture and tethers the electrical cable to the moving platform. Power requirements are USA standard, three-prong, 110-120 VAC, 60 Hz, 3 Amps or less.

Inca makes a wide range of standard products composed of different sizes, net travel dimensions, lift capacities, and combinations of accessories from which you can choose an appropriate lift for your application. If none of our standard stocked lifts will meet your needs, we can alter or modify any of these other products to fit your application. The lift is available in one size and one lifting capacity with the controls as specified. The lift will move any object or TV that is 29" wide or less and 26.5" high or less and weighs 200 lbs. or less.

ITEM NUMBER	DESCRIPTION	WIDTH	DEPTH	HEIGHT	NET TRAVEL	CAPACITY
900200	Standard	31.625"	17.000"	30.000"	26.5"	200 lbs.

TV LIFT P/N 900200

