

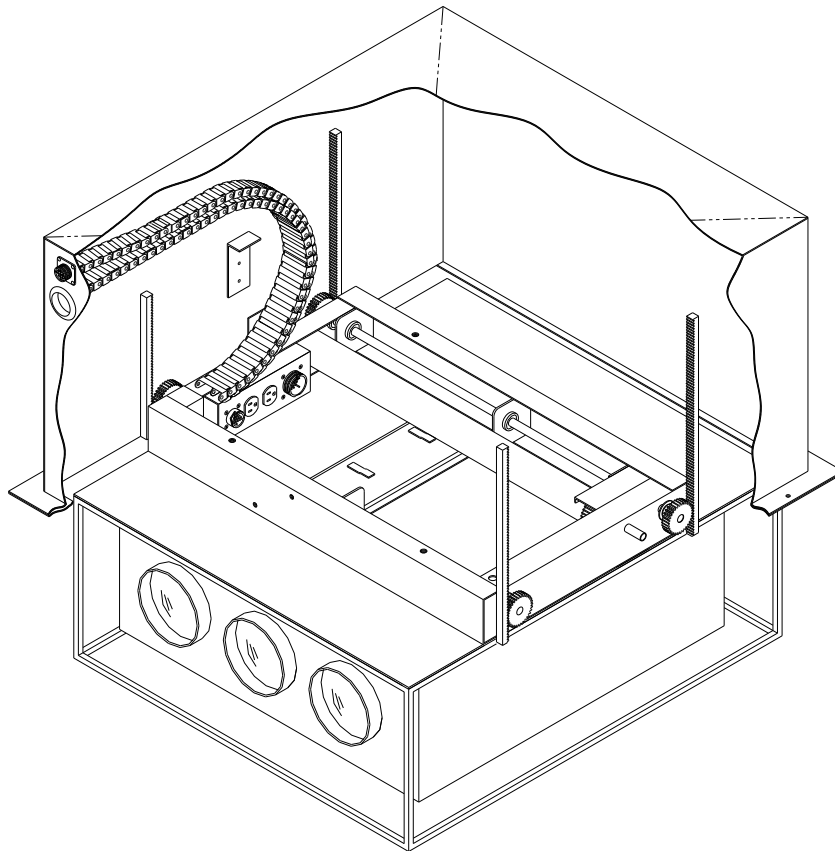

# PROJECTOR LIFT P/N 900411 100-400

1632-1/2 West 134<sup>th</sup> Street, Gardena, California 90249  
(310) 808-0001 Fax (310) 808-9092 [www.inca-tvlifts.com](http://www.inca-tvlifts.com)

The Inca Projector Lift is specifically configured to carry projectors that are installed in the ceiling. A smooth and accurate rack and pinion drive system ensures that the projector stops in the same place every time. Units are available in two standard sizes. Custom dimensions and lift capacities are readily available. These machines are totally enclosed and fabricated from aluminum. The external remote J-box comes with 25' of cable so that all of the connections for power and controls are done at an accessible location. Included with the lift is a sturdy 1/8" steel plate for mounting the projector. Also included is a 3/8" steel cage that will allow the installation of a sealing plate to cover the projector when it is retracted in the ceiling. Inca includes a set of rolling cable trays. One set is for Inca's control cables, which are connected to the machine via an aircraft multi-pin connector. The other set is for the customer's grommeted port on the wall of the machine and then into a large rolling cable tray expressively installed for this purpose. These machines are shipped fully assembled and ready for installing the projector inside of them.



ITEM NUMBER	DESCRIPTION	LIFTING CAPACITY	OVERALL DIMENSIONS	INTERNAL DIM. OF PROJECTOR CASE	PROJECTOR MOUNTING PLATE
900411-100A	Compact	100	26.650"W x 23.250"D x 19.25"H	21.375"W x 20"D x 14.125"H	21.375"W x 20"D x 0.125"Tk
900411-200A	Standard	200	29.875" x 32.70"D x 18"H	27.0"W x 31.70"D x 14.125"H	27"W x 31.70"D x 0.125"Tk
900411-400	Custom	Varies	Varies	Varies	Varies

# PROJECTOR LIFT

P/N 900411 -100 THRU -400

1/8" ALUMINUM ENCLOSURE

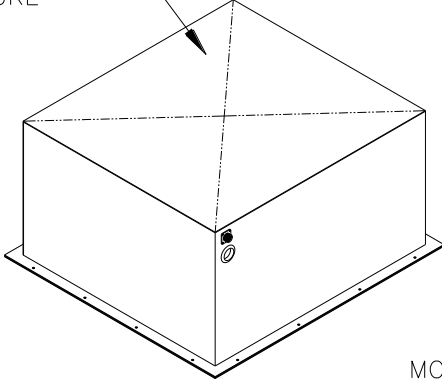

UNIT EXTERIOR

DUAL ROLLING CABLE TRAYS FOR CUSTOMER'S CABLE MANAGEMENT

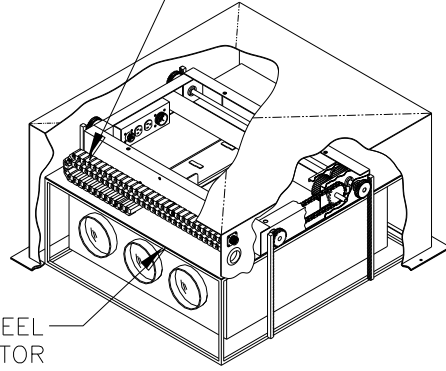

1/8" STEEL PROJECTOR MOUNTING PLATE

UNIT INTERIOR

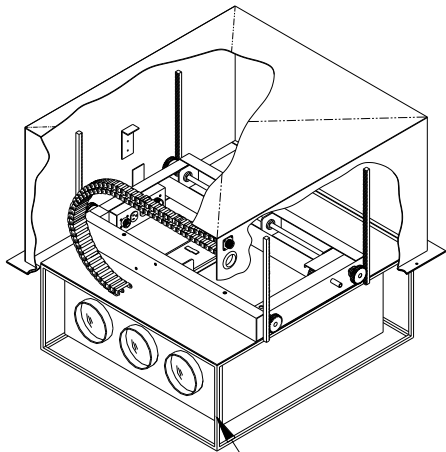

UNIT LOWERED

3/8" STEEL PROJECTOR CAGE

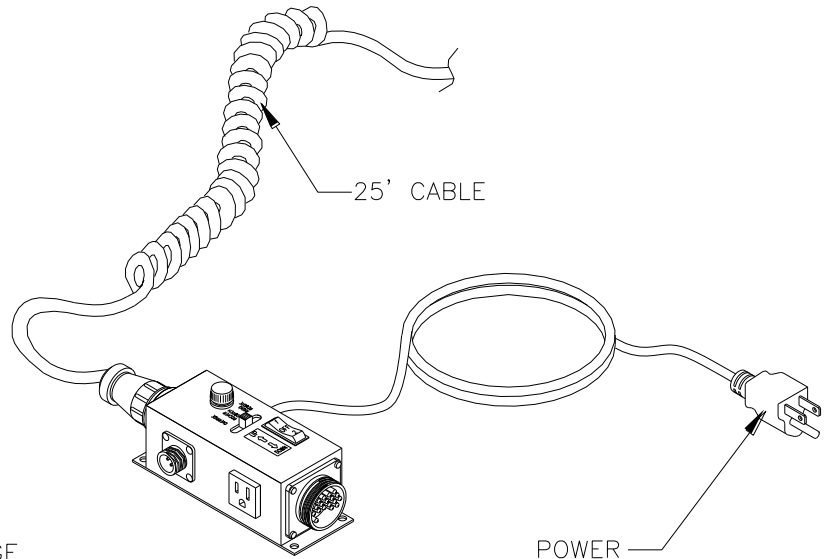

EXTERNAL JUNCTION BOX

POWER PLUG