

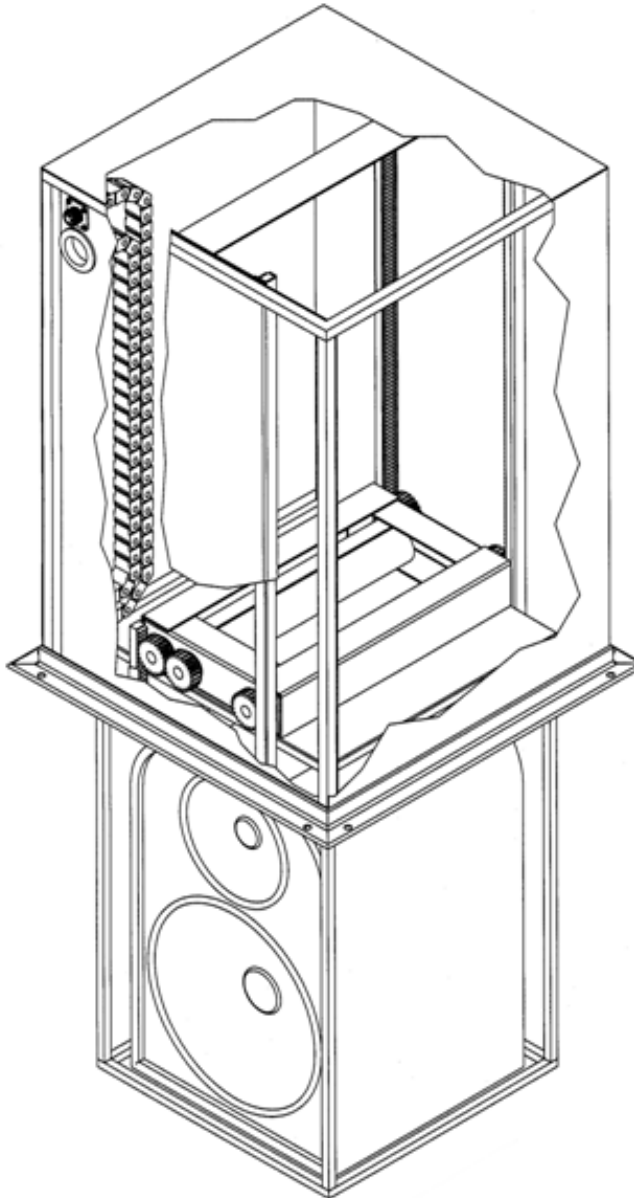

## SPEAKER LIFT P/N 900411-SPKR

1632-1/2 West 134<sup>th</sup> Street, Gardena, California 90249  
(310) 808-0001 Fax (310) 808-9092 [www.inca-tvlifts.com](http://www.inca-tvlifts.com)



The Inca Speaker Lift is specifically designed to lower or raise speakers from a concealed position such as in the ceiling, floor, sidewalls, or cabinetry. Completely self-contained, these precise rack and pinion driven lifts will move speakers up to 70 pounds in weight with accuracy and high-reliability. Standard units will accommodate a speaker whose weight is less than 70 pounds and whose dimensions are no more than 12.00”W x 12.00”D x 20.50”H. Custom lifts are readily available to fit other dimensional requirements. Each unit is fabricated from 18 g CRS tubing, covered with an aluminum skin. A 1” width steel mounting frame is also provided. Cable management is achieved by rolling cable trays for both customer’s speaker cables and Inca signal and power cabling to the lift assembly. Controllers are readily attachable to a remotely located, external junction box on 25’ of supplied cable. The j-box can connect any combination of Inca controllers, including simple switches, infrared systems, radio remotes, 12 vdc and dry contacts for touch-screen use. Also located on the external j-box is the input fuse and a built-in rocker switch, to control the unit in case the controller doesn’t work. This unit is shipped completely assembled, ready for installation.

ITEM NUMBER	DESCRIPTION	OVERALL ENCLOSURE DIMS. W/O FLANGE	INTERNAL DIMS. OF SPEAKER CAGE	LIFT CAPACITY
900411-SPKR	Standard	15.875”W x 15.75”D x 24.125”H	12.125”W x 12.125”D x 20.625”H	70 lbs.
900411-400-SPKR	Custom	Varies	Varies	Up to 100 lbs.

# SPEAKER LIFT P/N 900411-SPKR

4 pin connector and  
speaker wire access both  
supplied with the rolling  
cable tray

Precision rack and pinion  
drive system

.080 aluminum sealing  
plate

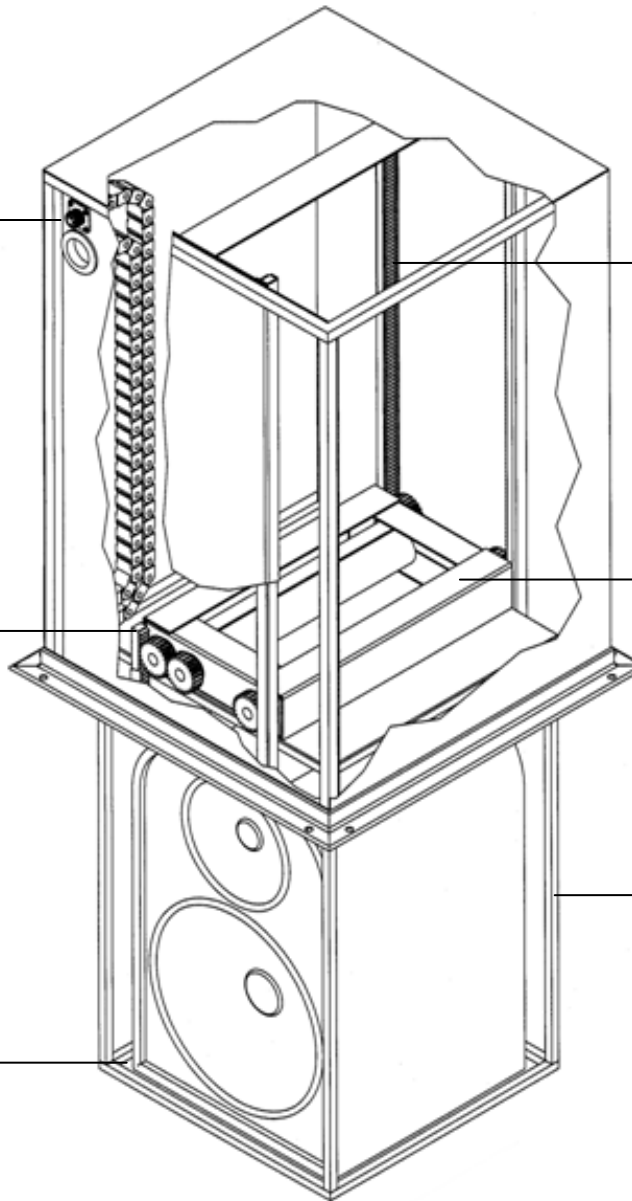

Aluminum, 1/2" faced rack  
gears for smooth and  
silent operation

2" thick, 70 lb. capacity  
aluminum lifting platform

3/8" CRS tubing cage