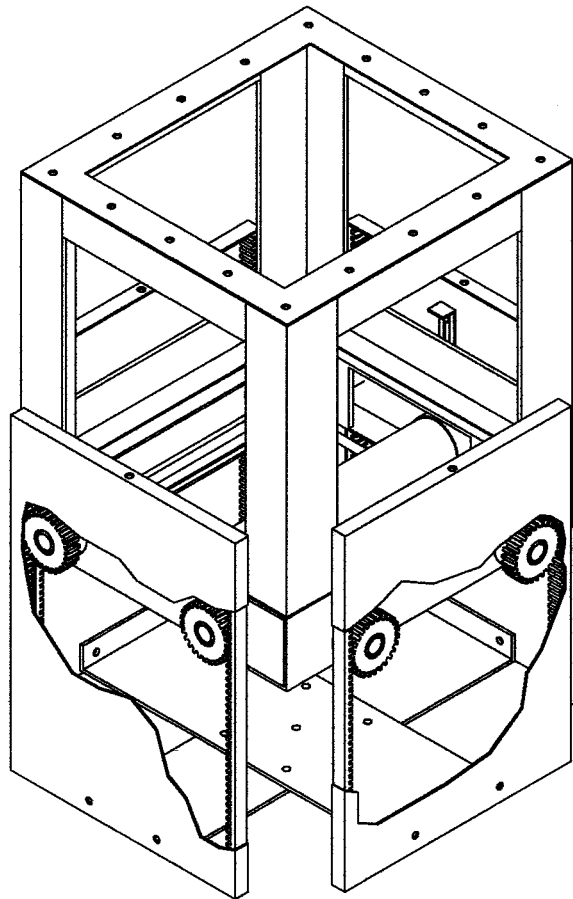



**TABLE LIFT  
P/N 900420**

**1632-1/2 West 134<sup>th</sup> Street, Gardena, California 90249  
(310) 808-0001 Fax (310) 808-9092 [www.inca-tvlifts.com](http://www.inca-tvlifts.com)**

The Inca Table lift assembly P/N 900420, models 1 and 2 are compact gear driven lifting mechanisms that are configured for installation inside of a pedestal mount that holds a tabletop. Operation of the machine raises the table top from a coffee table height to a height suitable for sit-down dining. This mechanism is constructed of aluminum and stainless steel and employs steel axles and gears for a long maintenance free life. Four side panels with cross axle transverse drive (see illustration overleaf) ensure rock solid stability of the table surface even when it is subject to extreme offset loads. The table lifts are ideal means of getting “double-duty” out of restricted space such as in yachts, motor homes and small apartments. Each lift has connections to allow the use of Inca controls, which include: radio remote, rocker switch, 12 VDC and dry contact closure signals for touch-screen use. The footprint of the mechanism is only 19.75”wide by 13.625” in depth, which provides a small, simple, rock solid and rugged solution to automate tables from one height to another.



ITEM NUMBER	LIFT CAPACITY	OVERALL DIMENSIONS	PLATFORM THICKNESS	VERTICAL TRAVEL
900420-1	250 lbs.	19.75”W x 13.625”D x 17”H	4.00”	13.00”
900420-2	450 lbs.	19.75”W x 13.625”D x 17”H	4.50”	12.50”
900420-400	Varies	Varies	Varies	Varies

TABLE LIFT  
P/N 900420

