

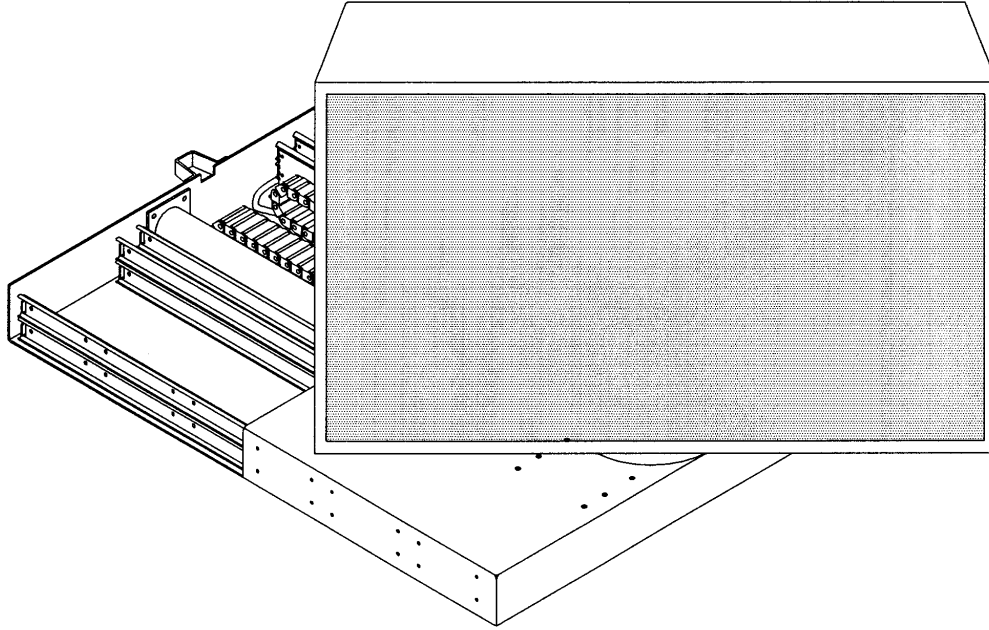

**FLAT SCREEN TV PULLOUT
AND SWIVEL MECHANISM
P/N 900500-PS**

1632-1/2 West 134th Street, Gardena, California 90249
(310) 808-0001 Fax (310) 808-9092 www.inca-tvlifts.com



The Inca Flat screen TV Pullout and Swivel Mechanism, 900500-PS can be used to move a flat screen screen out of an entertainment center or away from a wall, and turn the unit to any viewing angle. Strong and rigid, the base and moving components are made of 1/8" steel plate finished in semi-gloss black. The 5.75" Micro-swivel or the 8.50" heavy-duty swivel ring, are driven by a synchronous motor. The unique rolling cable tray allows for complete wire management of audio, video, and power cables. This system can be attached to a lift that will allow remote, automatic radio control for up/down, in/out, and left/right functions. A touch screen compatible controller that responds to 12 VDC or dry contact closure is also available. The magnetic cams allow the default stops on the swivel to provide any desired viewing angle. The automatic center finding feature fully interlocks the system so that it will not retract until it is at "zero" point, which is self-locating.

ITEM NUMBER	DESCRIPTION	OVERALL WIDTH	OVERALL DEPTH	OVERALL THROW	OVERALL THICKNESS
900500-PS1	Plasma LCD pullout and swivel Light Duty - flat screen screens up to 28"	12.00"	19.00"	18.00"	5.00"
900500-PS2	Flat screen TV pullout and swivel Moderate Duty - flat screen screens up to 42"	30.00"	25.00"	24.00"	5.00"

FLAT SCREEN TV PULLOUT AND SWIVEL MECHANISM P/N 900500-PS

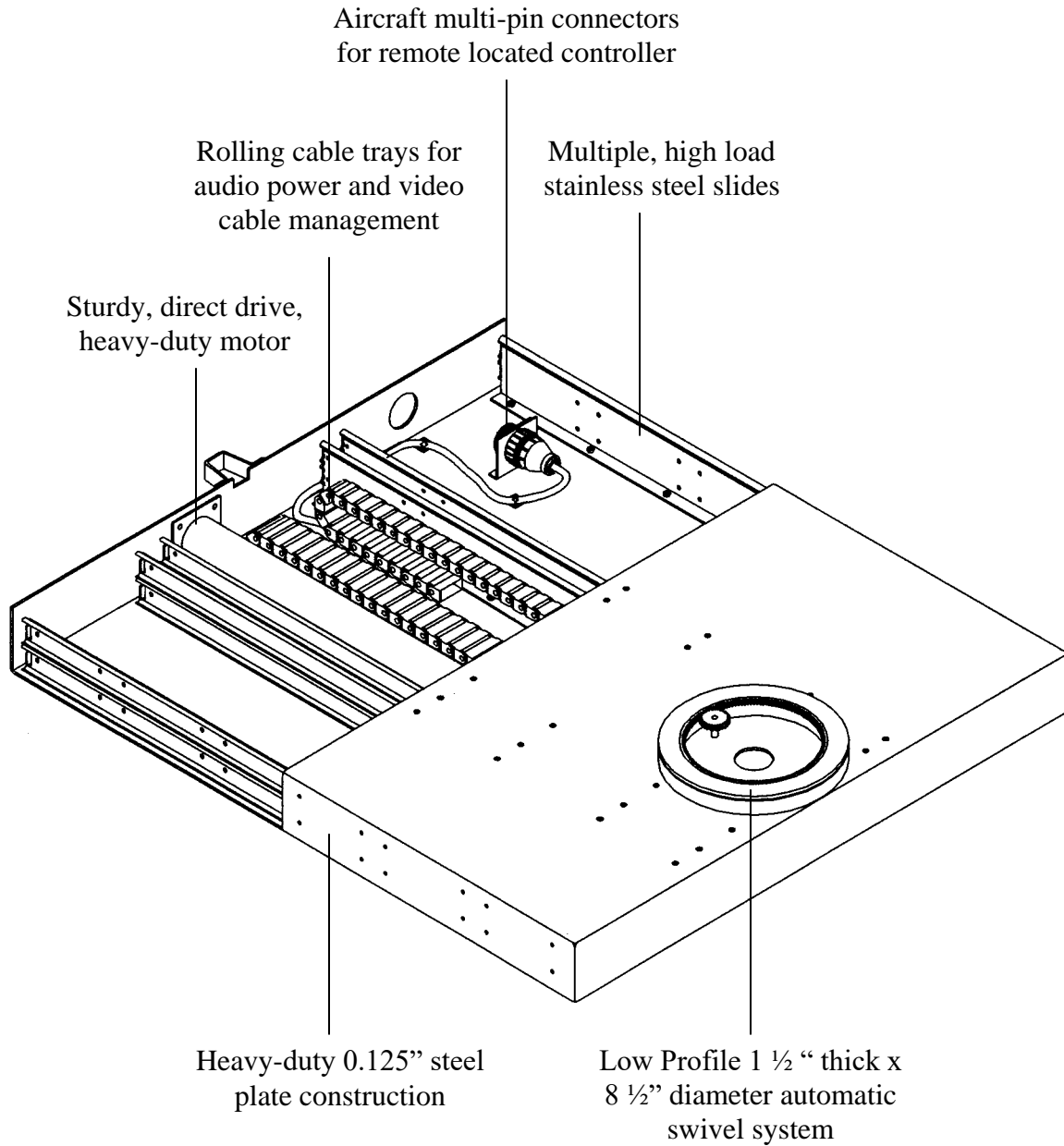

Model PS2 is shown for illustrative purposes