



HORIZONTAL DOOR OPENING MECHANISM P/N 900806-H

1632-1/2 West 134th Street, Gardena, California 90249
(310) 808-0001 Fax (310) 808-9092 www.inca-tvlifts.com

The P/N 900806-H is a modular door opening system that consists of an aluminum track and rail system with a modular motorized truck assembly that carries a door on the track. The truck is mounted on the track gear and is a self-contained driving assembly. The truck can be equipped with a mechanical clutch, which allows the door to stop when encountering an obstacle and to complete its cycle when the obstacle is cleared. The modular system includes a junction box mounting plate, which can be installed on either end of the track. This makes the door open from either the left or right side. In addition, the universal mounting plate allows a second module, of the same part number, to be installed in series with the primary module, thus providing a dual opening door control system. All units are custom made in either single or dual truck format, based on provided panel dimensions.

Aircraft AMP connectors allow for easy installation of various control options including Dry Contact Relay (P/N 900823-A), Power Sensor (P/N 900822-200), or the Radio Remote (P/N 900820).

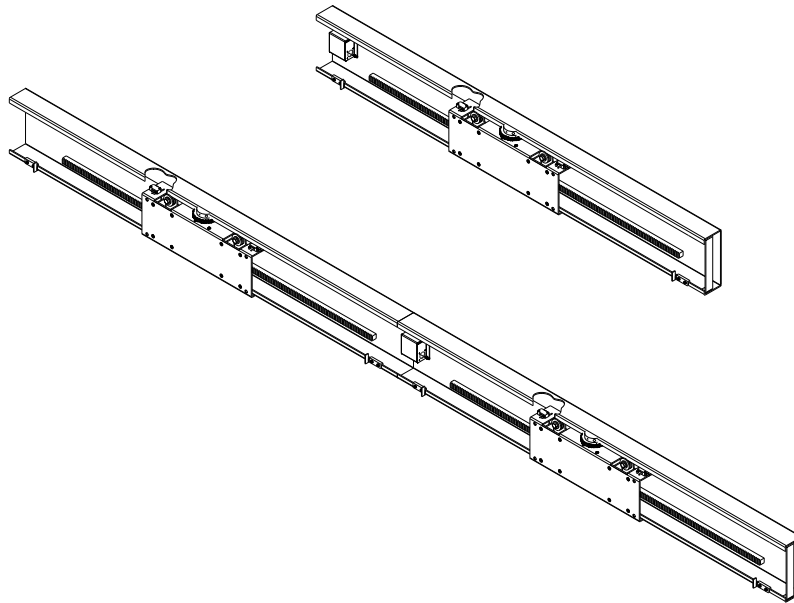

ITEM NUMBER	DESCRIPTION	MAX. SINGLE DOOR WIDTH	MAX. DOUBLE DOOR WIDTH	MAX. SINGLE DOOR WEIGHT
900806-H1-400-NP	Custom Door Opener, Single Track, Single Truck (Narrow Profile)	None	None	150 lbs.
900806-H2-400-NP	Custom Door Opener, Single Track, Dual Truck (Narrow Profile)	None	None	150 lbs.
900806-H1-400-WP	Custom Door Opener, Single Track, Single Truck (Wide Profile)	None	None	150 lbs.
900806-H2-400-WP	Custom Door Opener, Single Track, Dual Truck (Wide Profile)	None	None	150 lbs.

HORIZONTAL DOOR OPENING MECHANISM P/N 900806-H

