

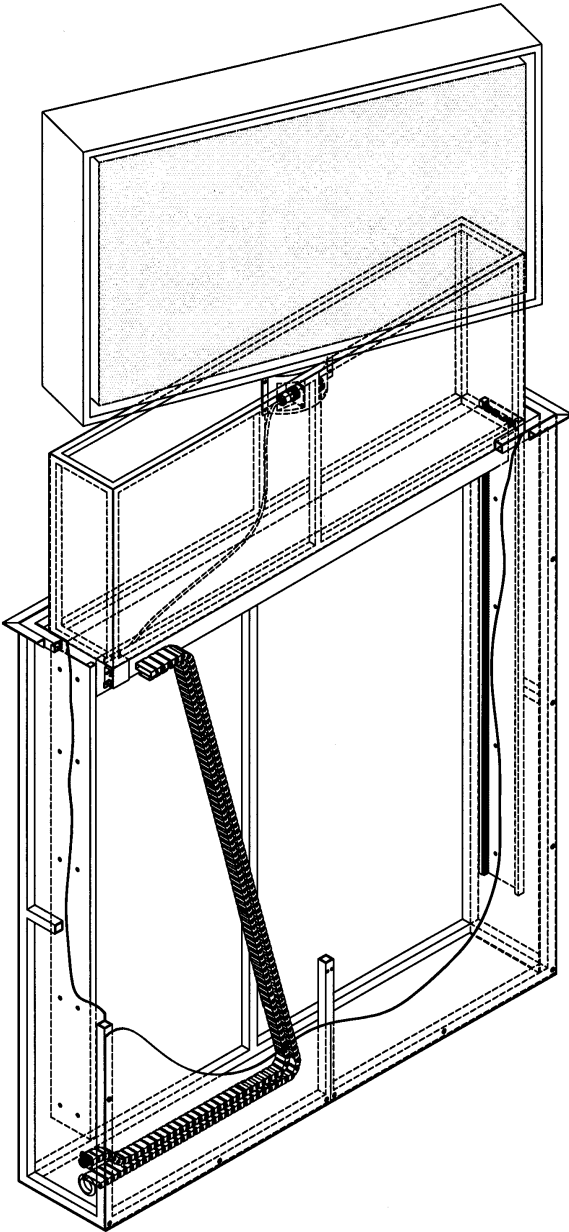

**FLAT SCREEN TV FLOOR LIFT
WITH BOX EXTENSION AND SWIVEL
P/N 900814-400-FBE-S**

1632-1/2 West 134th Street, Gardena, California 90249
(310) 808-0001 Fax (310) 808-9092 www.inca-tvlifts.com



The Inca Flat Screen TV Floor Lift with Extension Section and Swivel, P/N 900814-400-FBE-S provides a positive means of storing a flat screen display in the floor, raising it, and then swiveling it to any desired viewing angle. The remote swivel can be controlled by RF dual channel radio remote or optional touch-screen programmed 12 VDC/dry contact closures or signals. The enclosure is fabricated from 18-gauge CRS tubing, covered with a painted CRS sheet. The rigid, tubular frame keeps the casement in proper shape. Also provided are aircraft multi-pin connectors for control, power, and signals to the external controller. A generous 25' of cable is provided so the external j-box with its controller attached, can be located to a more accessible point such as an equipment room. The external j-box has a fuse, power input, and a function selection switch, which when operated, overrides all of the controls and brings the unit up immediately. Also included inside of the enclosure are rolling cable trays: one for the machine to provide signals and power, the other for the customer's cabling to the flat screen TV. Access to this larger rolling cable tray is through a 1 7/8" diameter grommeted port. The cable tray unzips to allow audio and video cables to be easily installed. As an optional accessory, Inca can provide a moving enclosure on

which the TV can be readily mounted. Furthermore, the extension box that holds the TV and enclosure attaches it to the swivel and lift, can be fabricated to almost any dimension to provide additional vertical rise from the floor to any desired viewing position.

| ITEM NUMBER | DESCRIPTION | WIDTH | DEPTH | HEIGHT | EXTENSION | RISE |
|------------------|--|--------|--------|--------|-----------|--------|
| 900814-400-FBE-S | Custom Flat Screen TV Floor Lift with Box Extension and Swivel | Varies | Varies | Varies | Varies | Varies |

FLAT SCREEN TV FLOOR LIFT WITH BOX EXTENSION AND SWIVEL P/N 900814-400-FBE-S

