

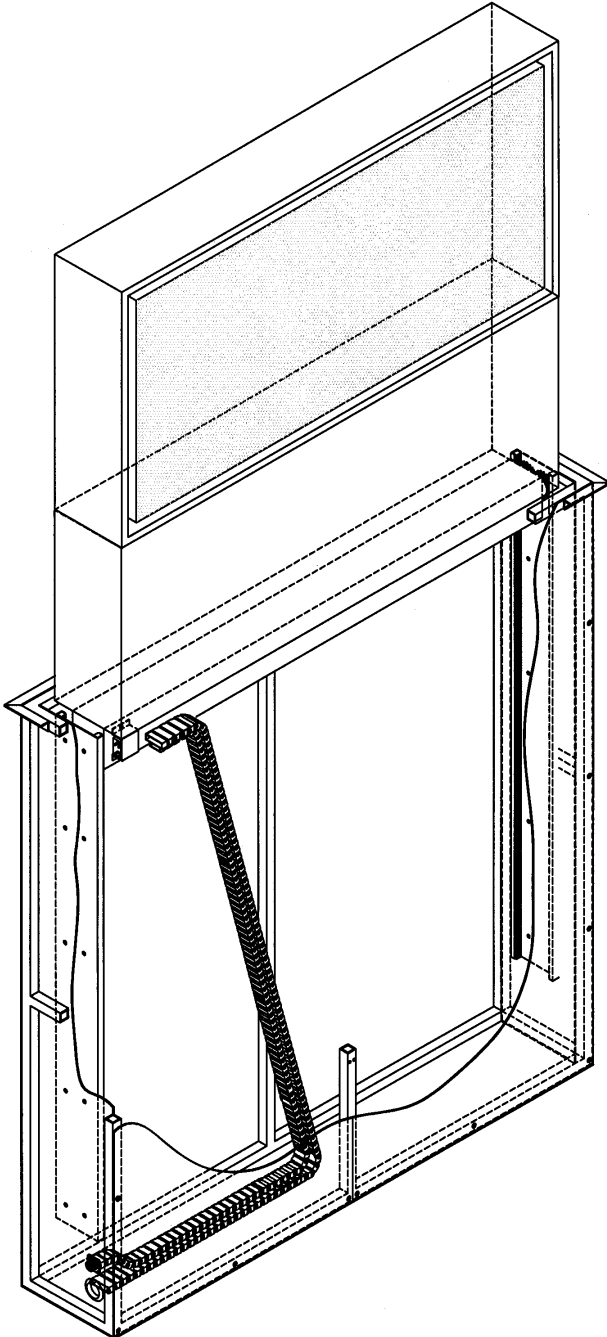

**FLAT SCREEN TV FLOOR LIFT  
WITH BOX EXTENSION SECTION  
P/N 900814-400-FBE**

1632-1/2 West 134<sup>th</sup> Street, Gardena, California 90249  
(310) 808-0001 Fax (310) 808-9092 [www.inca-tvlifts.com](http://www.inca-tvlifts.com)



The Inca Flat Screen TV Floor Lift with Box Extension section, P/N 900814-400-FBE provides a positive means of storing a flat screen TV display in the floor and then raising it to a desired viewing height. The enclosure is fabricated from 18-gauge CRS tubing, covered with a painted CRS sheet. The rigid, tubular frame keeps the casement in proper shape. Also provided are aircraft multi-pin connectors for control, power and signals to the external controller. A generous 25' of cable is provided so the external j-box with its controller attached, can be located to a more accessible point such as an equipment room. The external j-box has the fuse, power input, and a function selection switch, which when operated, brings the unit up immediately. Also included inside of the enclosure are rolling cable trays: one for the machine to provide signals and power, the other for the customer's cabling to the flat screen TV. Access to this larger rolling cable tray is through a 1 7/8" diameter grommeted port. The cable tray unzips to allow audio and video cables to be easily installed. As an optional accessory, Inca can provide a moving enclosure on which the TV can be readily mounted. Furthermore, the extension body that holds the TV and enclosure, attaches it to the lift can be fabricated to almost any dimension to provide additional vertical rise from the floor to any desired viewing position.

ITEM NUMBER	DESCRIPTION	WIDTH	DEPTH	HEIGHT	EXTENSION	RISE
900814-400-FBE	Custom Flat Screen TV Floor Lift with Box Extension	Varies	Varies	Varies	Varies	Varies

# FLAT SCREEN TV FLOOR LIFT WITH BOX EXTENSION SECTION P/N 900814-400-FBE

