

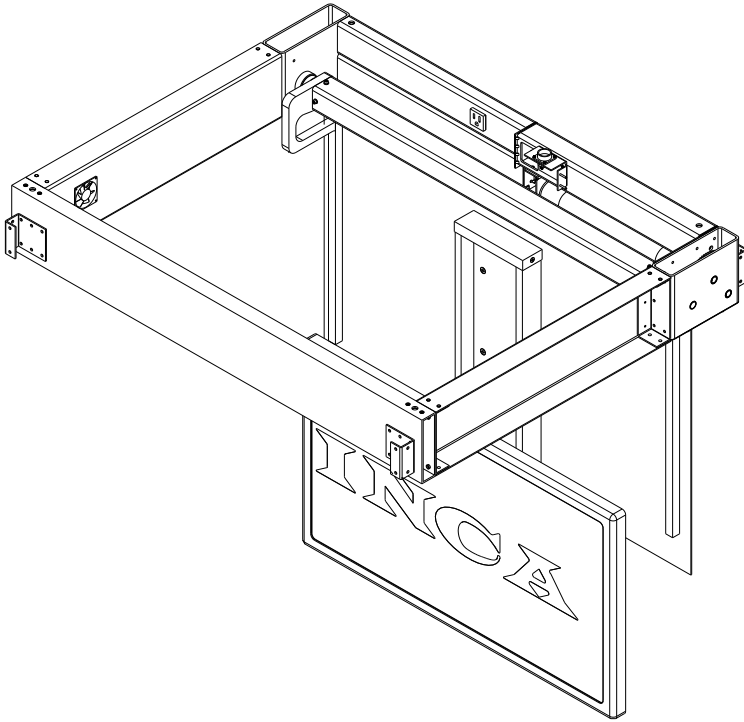

**FLAT SCREEN TV FOLD DOWN AND  
EXTEND CEILING UNIT (MODEL #2)  
P/N 900814-410-400-Q and 900700-400-V**

**1632-1/2 West 134<sup>th</sup> Street, Gardena, California 90249  
(310) 808-0001 Fax (310) 808-9092 [www.inca-tvlifts.com](http://www.inca-tvlifts.com)**



The Inca Flat Screen TV Fold-Down and Extend Ceiling unit is specifically designed to store TV's in the ceiling and upon command, lower the screen into a room and then extend it lower to the floor, for a perfect viewing position. This motorized mechanism is constructed of steel and aluminum and powder coated black for long life. All units include a mount to hang the TV. Control options are connected via a UJBX configured external J-box on the lift chassis via an aircraft 24-pin screw on connector. The external J-box is provided with 25' of cable so that it can be mounted in a conveniently accessible location. Choices of control options for the 900814-410-400-Q and 900700-400-V are simple rocker switch, RF radio remote, infrared transponder system, and 12 VDC/Dry contact closure for touch-screen applications. The external J-box also has a selector switch to choose various control modes and a built-in rocker switch. The unit has four corner bracket mounting frames to permit attachment of

the machine to the ceiling, via eight 1/4 -20 pem nuts (10 gage 0.125") and/or four 1/2 - 13 threaded holes on top. All Fold-down units contain a thermostatically controlled muffin fan to exhaust any accumulated heat above a preset limit, when the TV is stored inside the ceiling. Provisions are made to "unroll" the customer's video and power cables while the unit is deployed, as well as retract them when the unit is stored. A 110 plug is also provided at the unit. The motor can be removed and easily replaced, should this ever be needed, without having to remove the entire unit from its installation in the ceiling. A TV mounting plenum is also included to permit easy cable management and to enhance heat flow from the TV. A soft seal covers the shroud ceiling surface so that the unit is sealed completely when folded up into the closed position. The thickness of the assembly varies but the thickness for a typical Fold-down and Extend Ceiling unit (Model #2) is generally 8.00". The unit weighs approximately 400 lbs. and is shipped in a special crate to prevent shipping damages. It operates on US Standard, 110 VAC, 60 Hz power, but can be configured for use anywhere in the world via the selection of accessory packages. This system complies with CE marking requirements.

ITEM NUMBER	DESCRIPTION	WIDTH	DEPTH	HEIGHT
900814-410-400-Q & 900700-400-V	Custom Fold-Down and Extend (Model #2)	Varies	Varies	Varies

**FLAT SCREEN TV FOLD DOWN AND EXTEND CEILING UNIT (MODEL #2)**  
**P/N 900814-410-400-Q and 900700-400-V**

