

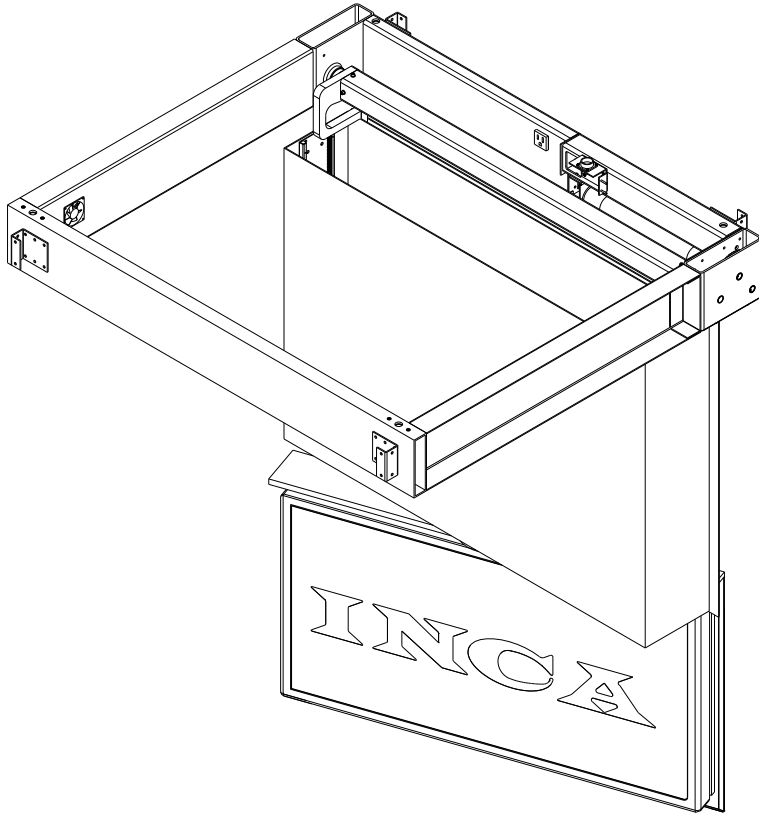

**FLAT SCREEN TV FOLD DOWN, EXTEND AND SWIVEL CEILING UNIT
P/N 900814-410-EXS-400**

1632-1/2 West 134th Street, Gardena, California 90249
(310) 808-0001 Fax (310) 808-9092 www.inca-tvlifts.com



The Inca Flat Screen TV Fold-Down, Extend, and Swivel Ceiling unit is specifically designed to store flat screen TVs in the ceiling and upon command, lower the flat screen TV into a room, extend it lower to the floor, and then rotate it for a perfect viewing position. This motorized mechanism is constructed of steel and aluminum and powder coated black for long life. All units are ready for TV installation. Control options are connected via a UJBX configured external J-box on the lift chassis via an aircraft 24-pin screw on connector. The external J-box is provided with 25' of cable so that it can be mounted in a conveniently accessible location. Choices of control options for the 900814-410-EXS-400 are a two-button RF radio remote or a two-motion sensor for touch-screen commands. The external J-box also has both a selector switch to choose various control modes and a built-in rocker switch. The unit has four corner bracket mounting frames to permit attachment of the machine to the ceiling, via eight ¼ -20 pem nuts (10 gage 0.125") and/or four ½-13 threaded holes on the top of the unit. All of our Fold-down units contain a thermostatically controlled muffin fan to exhaust any

accumulated heat above a preset limit, when the flat screen TV is stored inside the ceiling. Provisions are made to "unroll" the customer's video and power cables while the unit is deployed, as well as retract them when the unit is stored. The motor can be removed and easily replaced should this ever be needed, without having to remove the entire unit from its installation in the ceiling. A TV mounting plenum is also included to permit easy cable management and to enhance heat flow from the TV. A soft seal covers the shroud ceiling surface so that the unit is sealed completely when folded up into the closed position. The thickness of the assembly varies, but the thickness of a typical Fold-down, Extend and Swivel ceiling unit is generally 12.00". The unit weighs approximately 400 lbs. and is shipped in a special crate to prevent shipping damages. It operates on US Standard, 110 VAC, 60 Hz power, but can be configured for use anywhere in the world via the selection of accessory packages. This system complies with CE marking requirements.

ITEM NUMBER	DESCRIPTION	WIDTH	DEPTH	HEIGHT
900814-410-EXS-400	Custom Fold-Down, Extend, and Swivel	Varies	Varies	Varies

FLAT SCREEN TV FOLD DOWN, EXTEND, AND SWIVEL CEILING UNIT P/N 900814-410-EXS-400

