

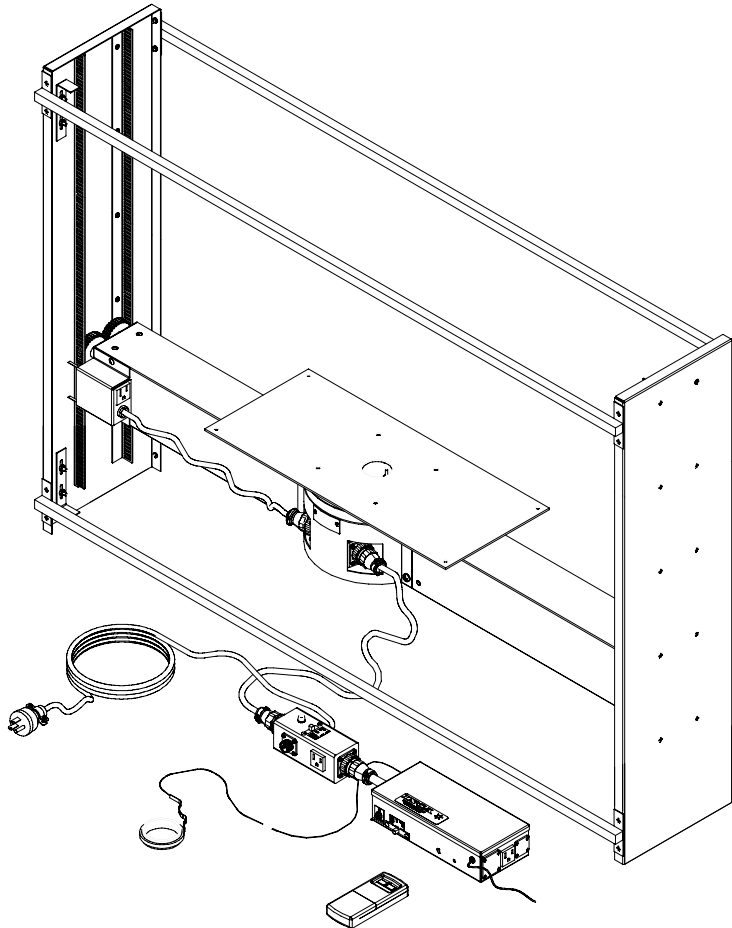

**INCA 'ADVANTAGE PLUS' 42" PLASMA TV LIFT  
WITH SWIVEL  
P/N 900828-1SA**

1632-1/2 West 134<sup>th</sup> Street, Gardena, California 90249  
(310) 808-0001 Fax (310) 808-9092 [www.inca-tvlifts.com](http://www.inca-tvlifts.com)



The Inca 'Advantage Plus' family of Plasma TV Lifts is specifically designed to accommodate the needs of a furniture manufacturer or cabinetmaker. The Advantage Plus P/N 900828-1SA can accept an automatic swivel, and covers all 42" plasma TVs with enclosures that weigh up to 200 lbs. These units are available 'knock down' for convenience in shipping. All units include a radio remote control and Inca's new touch-stop sensing technology that will reverse the downward motion of the machine if someone were to touch the sensor. Also included is a complete universal mounting frame to mount and support the plasma TV. All units are finished in semi-gloss black. **An enclosure is not supplied unless specified.**

This product is American-made, and bears a full two year warranty, backed by a network of over 1000 Inca dealers nationwide.

MODEL	OVERALL DIMENSIONS	PLATFORM DIMENSIONS	SWIVEL	TRAVEL	CAPACITY
900828-1SA	50.75"W x 10.25"D x 37.875"H	48.125"W x 3.625"D x 5.50"H	YES	32.00"	200 lbs.

# INCA 'ADVANTAGE PLUS' 42" PLASMA TV LIFT WITH SWIVEL P/N 900828-1SA

